



# HUBER+SUHNER®

## SENCITY® RAIL ANTENNA

### FOR WIRELESS COMMUNICATION



#### SWA 0859/360/4/0/DFRX30

**Multiband antenna: GSM 900, GSM 1800, GSM/PCS 1900, UMTS, 2.4, 3.5, 5.3 and 5.8 GHz Bands and GPS including LNA**

#### Technical Data

##### Electrical Properties Broadband Antenna

Frequency range (MHz)	870 - 960	1710 - 2170	2400 - 2700	3400 - 3700	5150 - 5875
Impedance	50 Ω				
VSWR	< 1.5	< 1.5	< 1.5	< 1.5	< 2.0
Polarization	linear, vertical				
Gain (using a 1 m <sup>2</sup> ground plane)	6 dBi	8.5 dBi	9.5 dBi	9.5 dBi	8.5 dBi
Max. power	400 W (CW) at 50°C				

##### Electrical Properties GPS Antenna

Frequency range	1575.42 ± 1.023 MHz				
Impedance	50 Ω				
VSWR	≤ 1.8				
Polarization	right hand circular polarized (RHCP)				
Antenna gain (using a 1 m <sup>2</sup> ground plane)	6 dBi (ref. to a circularly polarized isotropic antenna)				
Gain LNA	27 ± 2 dB				
Noise figure	≤ 2.7 dB, typ. 2 dB				
Operating voltage	3.0 to 5.5 VDC feed at centre conductor of GPS antenna				
Current consumption	≤ 25 mA, typ. 20 mA				
Out of band attenuation	> 20 dB at f <sub>0</sub> ± 50 MHz > 40 dB at f <sub>0</sub> ± 100 MHz				
Isolation between ports	> 30 dB	> 40 dB	> 40 dB	> 37 dB	> 28 dB

##### Mechanical Properties

Dimensions	260 x 100 x 90 mm (10.24" x 3.94" x 3.54") <i>without mounting accessory 9091.99.0189</i>				
Weight	1.2 kg (2.65 lbs.)				
Housing material	aluminium powder painted RAL 7043 (dark grey)				
Radome material	high impact acrylic styrene acrylonitrile (HRA150)				
Radome color	RAL 7043 (dark grey)				
Operating temperature range	- 30°C to + 85°C				
Storage temperature range	- 40°C to + 80°C				

Meets the following requirements:

- Degree of protection according to EN 60529 with splash waterproof level IP66 (only if correctly installed).
- EN 50155, electronic equipment used on rolling stock.
- EN 50124-1, insulation coordination (27.5 KV AC and 3.8 KV DC).
- High voltage and high current protection according to Deutsche Bahn specifications (protection against short circuits of 40 KA).
- EN 50121-3-2, electromagnetic compatibility.

##### Available Types

1399.17.0044	Article no.	84002818	2 x N female
--------------	-------------	----------	--------------

##### Mounting Hardware

9091.99.0189	Article no.	84008192	Adapter panel <sup>1</sup>
--------------	-------------	----------	----------------------------

<sup>1</sup>: Allowing the replacement of the antenna from another antenna manufacturer, without any modifications of the original mounting holes located on the vehicle's roof. Using this interface, the mounting holes dimension for the broadband and GPS connectors have to be 17 ... 42 mm and 35 ... 42 mm respectively (ref. to mounting instruction). The antenna has to be secured using four M10 screws.

##### Documents

01.02.0777	security instruction
01.02.1045	mounting instruction

**Material:** The antenna is designed according the military standard MIL-F-14072D, which guarantees a long-life without corrosion.

**Mounting:** On a plane conductive surface clear of paint and other contaminants.

To ensure a correct sealing between the antenna and the roof, the connector mounting hole dimensions have to be 17 ... 42 mm for the broadband antenna and 35 ... 42 mm for GPS antenna. The antenna has to be secured using four M8 screws.

**Grounding and high voltage protection:** All antenna parts are grounded to protect against lightning and catenary lines according to UIC 533.



# HUBER+SUHNER® SENCITY® RAIL ANTENNA FOR WIRELESS COMMUNICATION

**SWA 0859/360/4/0/DFRX30**

Dimensions (mm)

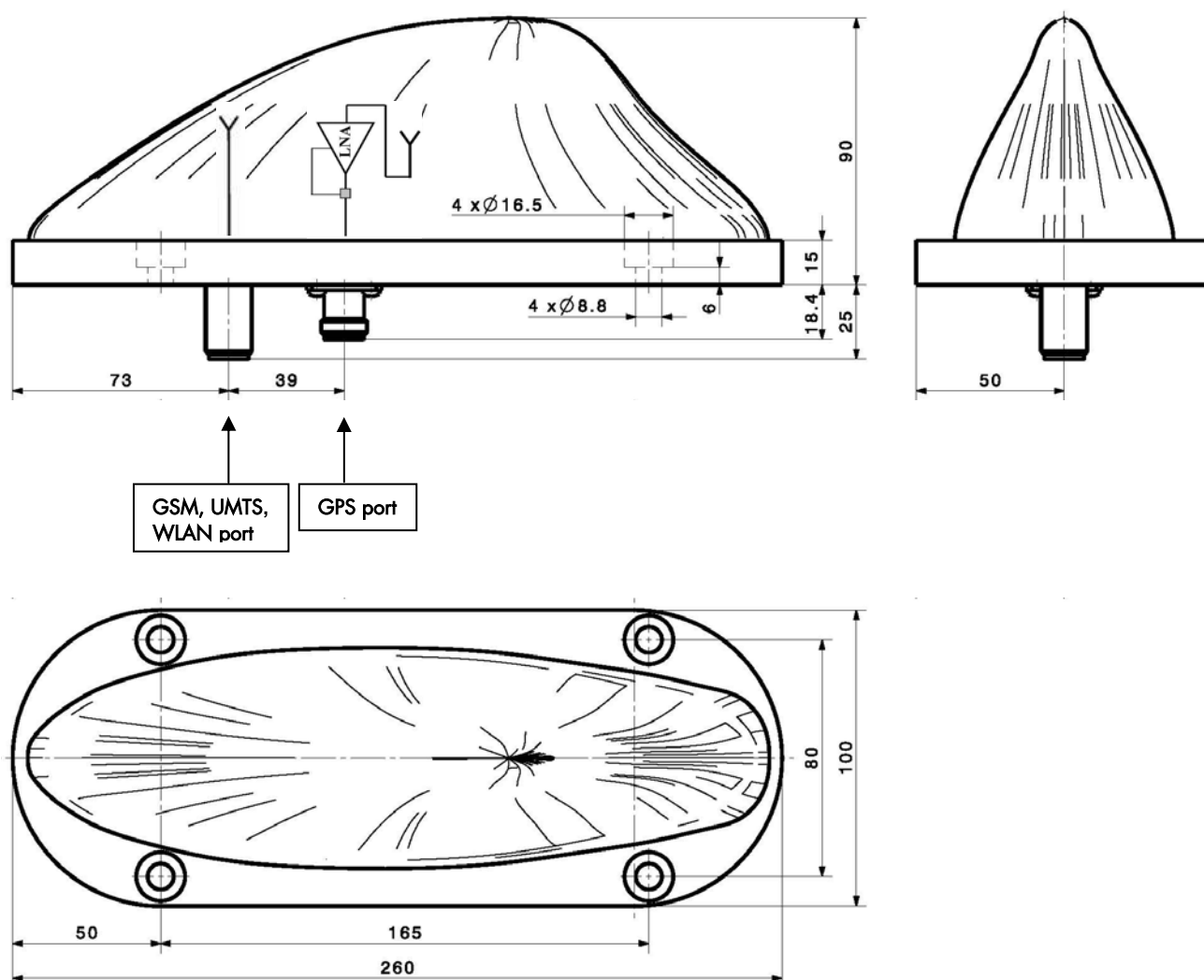



# HUBER+SUHNER® SENCITY® RAIL ANTENNA FOR WIRELESS COMMUNICATION

**SWA 0859/360/4/0/DFRX30**

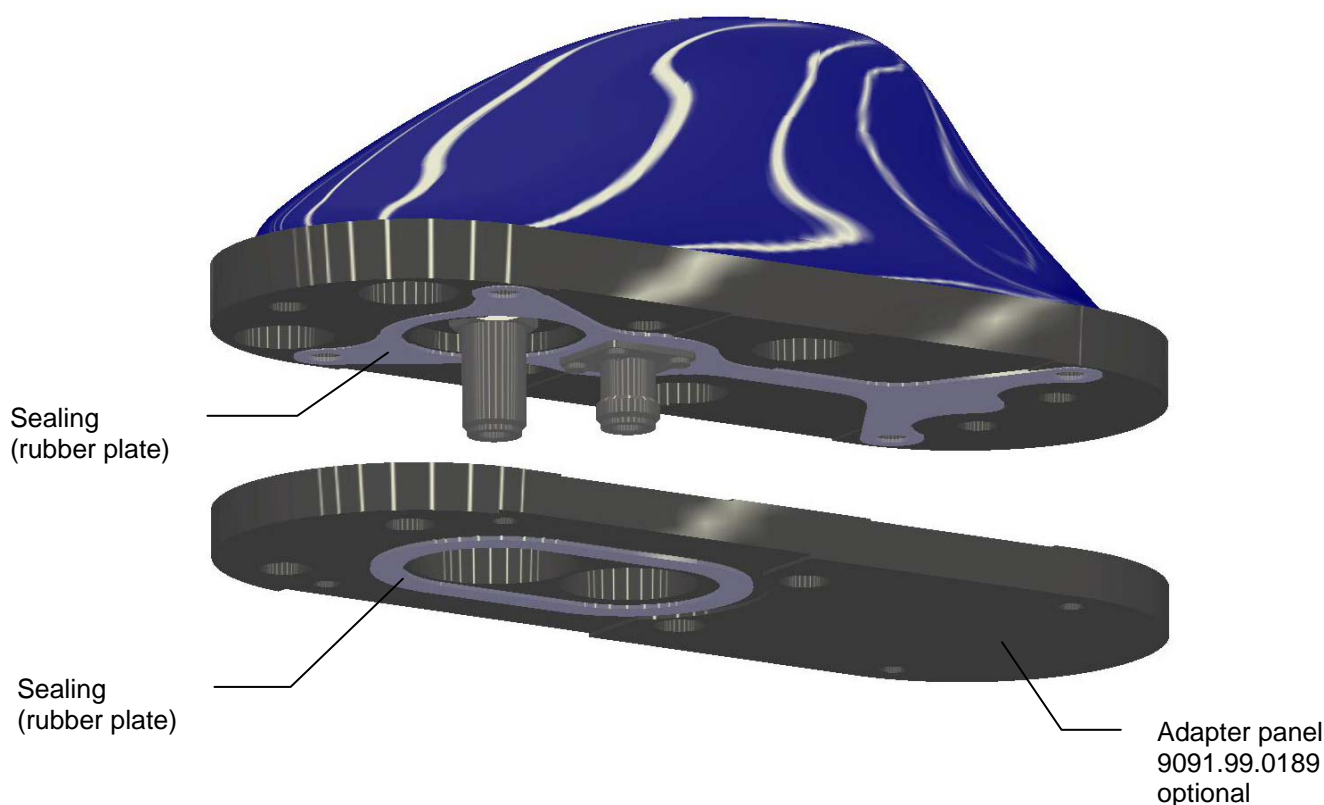

HUBER+SUHNER is certified according to ISO 9001 and ISO 14001

**WAIVER!**

It is exclusively in written agreements that we provide our customers with warrants and representations as to the technical contained specifications and/or the fitness for any particular purpose. The facts and figures herein are carefully compiled to the best of our knowledge, but they are intended for general informational purposes only.

**HUBER+SUHNER – Excellence in Connectivity Solutions**

Document no.: 01.02.0959  
Issue no.: 14  
Supersedes: 10.2004

**Uncontrolled Copy**

Issued/Checked/Released: 4159/4772/03.2005  
Last amended: 4159



**HUBER+SUHNER AG**  
**RF Technology**  
**9100 Herisau, Switzerland**  
Phone +41 (0)71 353 41 11  
Fax +41 (0)71 353 47 51  
[www.hubersuhner.com](http://www.hubersuhner.com)