

## 2.4 WLL 14-180 180° SECTOR ANTENNA FOR WLL 2.4 GHz



### ELECTRICAL DATA

ANTENNA TYPE	2.4 WLL 14-180
FREQUENCY RANGE	2.3 ÷ 2.5 GHz
IMPEDANCE	50 ohm
CONNECTOR	N f
MAX POWER	150 W
VSWR	≤ 1.5
POLARIZATION	Vertical
GAIN	14 dBi
HALFPOWERBEAMWIDTH	
Vertical plane	5°
Horizontal plane	180°
FRONT TO BACK RATIO	≥ 18 dB
LIGHTNING PROTECTION	All metal parts DC grounded

### MECHANICAL DATA

DIMENSIONS	1237 x 155 x 125 mm	
WEIGHT	5.7 Kg	
WIND SURFACE	Front	0.19 m <sup>2</sup>
	Side	0.06 m <sup>2</sup>
WIND LOAD	Front	250 N
(wind speed 150Km/h)	Side	80 N
ICING PROTECTION	Full radome	
RADOME COLOUR	Grey (std.) others on request	
MOUNTING	On wall or on pole	
PACKING	1330 x 175 x 150 mm	



### RADIATION PATTERNS (mid band)

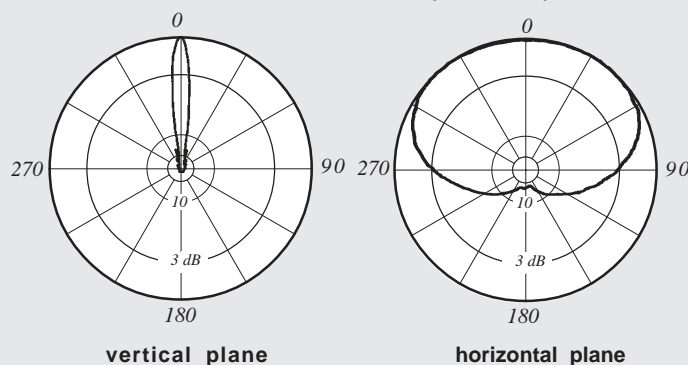

# ADDITIONAL INFORMATION



## ACCESSORIES

Type No.	Description	Remarks	Weight appr.	Units per antenna
734 360	2 clamps	Pole: 34 - 60 mm diameter	60 g	1
734 361	2 clamps	Pole: 60 - 80 mm diameter	70 g	1
734 362	2 clamps	Pole: 80 - 100 mm diameter	80 g	1
734 363	2 clamps	Pole: 100 - 120 mm diameter	90 g	1
734 364	2 clamps	Pole: 120 - 140 mm diameter	110 g	1
734 365	2 clamps	Pole: 45 - 125 mm diameter	80 g	1
738 546	1 clamp	Pole: 50 - 115 mm diameter	1.0 kg	2
732 327	1 downtilt kit	Downtilt angle: 0° - 10°	1.0 kg	1

Wall mountig: No additional mounting kit needed

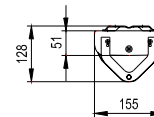
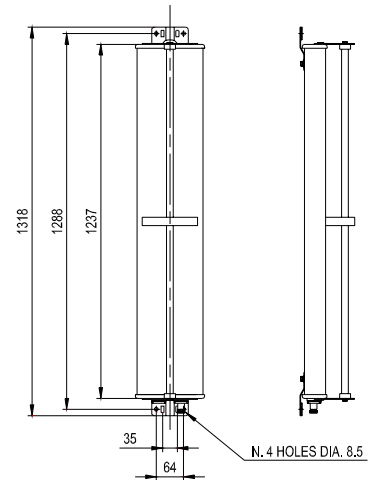

### Materials:

**Reflector screen:** Aluminium.

**Fiberglass radome:** The grey fiberglass radomes of these antennas are very stable and extraordinarily stiff. They are resistant to ultraviolet radiation and can also be painted to match their surroundings.

**All screws and nuts:** Stainless steel.

### Grounding:

All metal parts of the antenna including the mounting kit and the inner conductor are DC grounded.

### Environmental conditions:

SIRA cellular antennas are designed to operate under the environmental conditions as described in ETS 300 019-1-4 class 4.1 E.

Ice protection: Due to the very sturdy antenna construction and the protection of the radiating system by the radome, the antenna remains operational even under icy conditions.

### Environmental tests:

SIRA antennas have passed environmental tests as recommended in ETS 300 019-2-4.



### PLEASE NOTE:

As a result of more stringent legal regulations and judgements regarding product liability, we are obliged to point out certain risks that may arise when products are used under extraordinary operating conditions.

The mechanical design is based on the environmental conditions as stipulated in ETS 300 019-1-4, which include the static mechanical load imposed on an antenna by wind at maximum velocity.

Extraordinary operating conditions, such as heavy icing or exceptional dynamic stress (e.g. strain caused by oscillating support structures), may result in the breakage of an antenna or even cause it to fall to the ground. These facts must be considered during the site planning process.

The installation team must be properly qualified and also be familiar with the relevant national safety regulations.

The details given in our data sheets have to be followed carefully when installing the antennas and accessories.

The limits for the coupling torque of RF-connectors, recommended by the connector manufactures must be obeyed.